



## **APR FSI Fuel Pump Installation Notes, Recommendations, and Precautions**

### **PREFACE**

The installation of the APR FSI Fuel Pump onto any VAG 2.0T FSI engine should be carried out using all of the factory recommended installation procedures and precautions. The notes, recommendations, and precautions in this document are intended as a supplement to those already provided by VAG. **This entire document must be read and understood before attempting to install your APR FSI Fuel pump.**

**WARNING: Direct Injection FSI fueling systems run at very high pressures. The pressure in the fuel lines must be relieved prior to removal of the fuel pump to prevent serious bodily injury. Please consult a factory-approved repair manual (i.e. Bentley manual) for the proper procedures and precautions.**

### **INSPECTING YOUR VEHICLE BEFORE INSTALLING THE APR FSI PUMP**

To ensure that your vehicle is ready for the installation of the APR FSI pump, you must be aware of the condition of the mechanical components that drive the pump in your 2.0T FSI equipped vehicle. This is critical to the operation and longevity of your vehicle and your APR FSI Fuel Pump.

The high-pressure FSI fuel pump used in the 2.0T FSI equipped vehicles is mechanically driven by the intake camshaft and is therefore directly tied to the vehicle valve train assembly. In addition, there is a low-pressure feed pump at the fuel tank of your vehicle and a fuel filter with integral pressure-regulator that are important to the operation of the APR FSI pump. To add to the complexity, there are many auxiliary sensors and pressure relief valves that are all critical to the proper operation of the direct injection fueling system on your vehicle. It is the responsibility of the customer and/or the installer to ensure that all the vehicle components driving the FSI fuel pump are in good working order and are not in a state of excessive wear or failure prior to the installation of the APR pump.

Volkswagen of America, Inc. has released a Technical Service Bulletin (TSB) stating that there is a known problem concerning premature wear of the intake camshaft lobe and camshaft follower that drive the FSI high-pressure fuel pump. This wear has been known to cause fuel delivery issues and fuel rail pressure fluctuations. If this wear goes unchecked, wear can also begin on the base of the FSI high-pressure fuel pump. In some cases, this wear can result in a complete failure of the intake camshaft which may result in extensive damage to the engine valve train, head, and other related components. The published TSB describes the proper method for inspecting your vehicle for this type of wear and



also describes what steps should be taken to repair the damage through your factory-authorized service department. Please go to the internet link below to view a copy of the VW/Audi Technical Service Bulletin related to premature cam lobe wear:

[http://www.goapr.com/images/support/tsb/20t\\_cam\\_wear.pdf](http://www.goapr.com/images/support/tsb/20t_cam_wear.pdf)

**IT IS THE RESPONSIBILITY OF THE END-USER TO ENSURE THAT THE FUEL PUMP RELATED CAM LOBE, CAM FOLLOWER, AND ORIGINAL FUEL PUMP ARE IN PROPER WORKING ORDER PRIOR TO INSTALLATION OF THE UPGRADED APR FSI FUEL PUMP.** In addition, if the vehicle has had any issues related to fuel delivery prior to the installation of the APR pump, a thorough inspection of the other components related to fuel delivery may be necessary.

### **NOTES/RECOMMENDATIONS/PRECAUTIONS**

#### **Working with the FSI Fuel Pumps:**

1. Precautions should be taken to keep the FSI fuel pump in a clean environment free of dust, sand/grit, metal shavings, etc. prior to and during the installation process. *The pump should remain in a clean plastic bag until it is ready to be fitted to the vehicle.*
2. The APR FSI Pump will be shipped with all inlet, outlet, and pressure ports covered. These ports should remain covered until the last possible minute to ensure that there is no contamination within the pump chambers prior to installation
3. Take care not to drop the OEM or APR FSI Pump or subject it to any impacts prior to or during the installation process
4. Prior to installation of the OEM Pressure Sensor and/or Pressure Relieve Valve (Schrader valve) into the APR FSI Pump, make sure that the threads are clean of debris, sand/grit, and/or metal shavings, etc. The threads of these fittings can be cleaned with a standard brake cleaner while debris can be removed with a shot of compressed air.
5. The installation of your APR FSI Fuel Pump *may* require that you remove the fuel inlet fitting from your OEM supplied pump and install that fitting into your APR FSI Fuel Pump (based on part revision changes made by VW/Audi). You must check the type of fuel inlet fitting that is located on your original FSI fuel pump before starting the installation to ensure that you properly prepare your APR FSI pump for fitment on your vehicle. NOTE: the fuel *outlet* fitting should



not be removed or altered in any way. If a fitting change must occur, this will require you to remove the fuel inlet fitting from both your OEM supplied pump and your APR FSI Fuel Pump and install the OEM supplied inlet fitting into your APR pump in place of the fitting supplied by APR. Removal of each of these fittings should be done with care such that the minimum torque is applied with the proper tool to effect the removal and reinstallation of the fitting.

5.1. There are two types of fuel inlet fittings that VW/Audi uses for the high-pressure FSI fuel pump (see figures 1 and 2):

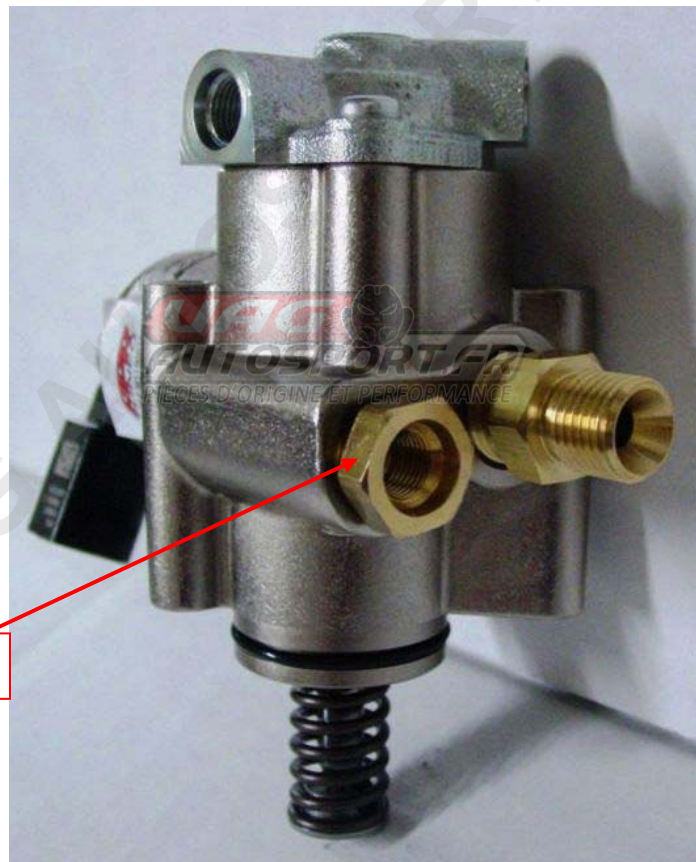

Banjo style fuel inlet fitting

FIG 1: FSI Fuel Pump shown with Banjo type fuel inlet fitting that is secured and sealed with a factory banjo fitting (already on vehicle fuel line) and a banjo-style bolt.



“Bamboo” style fuel inlet fitting

FIG 2: FSI Fuel Pump shown with “Bamboo” type fitting where a hose is pushed-on to the barbed fitting and secured with a hose clamp.

- 5.2. If you are purchasing a new (not a rebuilt) APR FSI Fuel pump, you will receive the pump with the “Bamboo” type barbed fitting. You will need to check the type of fitting that your vehicle was originally equipped with to determine whether or not your original fuel line is compatible with the Bamboo fitting. If your vehicle is directly compatible with the Bamboo fitting, you can install your APR FSI fuel pump without the need to remove and/or reinstall any of the fittings on the pump
- 5.3. If there is a need to change the fuel inlet fitting on your APR pump, this can be done given basic hand tools including: a 14mm socket or wrench (Bamboo fitting), a 17mm socket or wrench (Banjo fitting), a calibrated torque wrench, and a bench-top vise (for holding the pump in place while performing work)
- 5.4. You should install a clean, debris-free fitting into the APR pump and torque the fitting to 28Nm. Note: this is the tightening torque for the assembly of the Banjo or Bamboo-style fuel fitting into the pump only and



not the tightening torque for the banjo bolt that joins the fuel line to the pump if the banjo style fitting is being used.

6. Other than the removal and reinstallation of the fuel inlet fitting (as described in Note 5), the OEM Pressure Sensor, and the OEM Pressure Relief Valve (Schrader valve), DO NOT disassemble any parts of the APR FSI Fuel Pump. For information concerning the removal and reinstallation of the OEM Pressure Sensor or the OEM Pressure Relieve Valve, please consult a factory-authorized manual (i.e. Bentley Manual).

### **INSTALLATION OF APR PUMP**

- 1) With the engine cool, disconnect the negative terminal on the battery.
- 2) Remove the air duct to the factory airbox, and disconnect the MAF sensor wiring harness. Lift up and remove the factory airbox.
- 3) Disconnect the two electrical connectors from the top and side of the stock FSI fuel pump.
- 4) If equipped, remove the plastic cap from the Schrader-style fuel pressure release valve on the stock FSI fuel pump. Place a rag under the FSI fuel pump and depress the Schrader valve to release any additional fuel pressure.
- 5) If equipped, remove the pressure release valve from the FSI fuel pump, being careful not to strip the fitting.
- 6) Disconnect the two fuel lines from the bottom of the FSI fuel pump.
- 7) Remove the three bolts holding the FSI fuel pump to the cylinder head and carefully remove the pump.
- 8) If necessary, swap the fittings from your stock fuel pump to the APR FSI fuel pump. See the “NOTES/RECOMMENDATIONS/PRECAUTIONS” section above regarding the fittings on the fuel pump.
- 9) Swap the low fuel pressure sensor from the stock FSI fuel pump to the APR FSI pump and tighten to 15Nm.
- 10) Remove the cam follower and inspect as according to the factory TSB regarding cam and cam follower wear. If you are unsure or unable to determine as to whether the wear on your cam follower/cam are excessive, please contact APR or seek a second opinion before proceeding.
- 11) After determining that wear is not an issue, reinstall the cam follower. If you are using a new cam follower, be sure to use some moly grease on the camshaft side of the follower for initial break in.
- 12) Lubricate the o-ring on the outside body of the APR FSI pump with engine oil.
- 13) Carefully install the APR FSI pump in the cylinder head and hand tighten the three bolts.



- 14) Reinstall the fuel lines to the bottom of the APR FSI pump.
- 15) Torque the three bolts holding the APR FSI pump to the head to 10Nm. Tighten the union nut on the fuel line to 25Nm. If equipped, tighten the banjo bolt to 17Nm. If your car has a bamboo style fitting, reinstall the hose clamp on the fitting.
- 16) Reconnect the two electrical connectors to the APR FSI pump.
- 17) Reinstall the factory airbox, the air duct to the factory airbox, and the MAF sensor wiring harness.
- 18) Reconnect the negative battery terminal.

### **ROUTINE FUEL PUMP INSPECTION**

On a periodic basis, around every ten thousand (10,000) miles, APR recommends that you inspect the FSI fuel pump, cam follower, and camshaft in accordance with the factory TSB for abnormal wear. If any wear appears to have worn through the black wear coating on the cam follower, we recommend that you replace the cam follower. Once this black coating is worn off, the wear rate of the cam follower and lobe is dramatically increased. Keeping a good cam follower in the car is critical to the long term operation of your vehicle.

The cam follower and camshaft wear rates on even stock vehicles appears to be increased over what even VW/Audi has anticipated. We predict that VW/Audi will either supersede these components to increase their longevity or they will begin to include this inspection as a part of the routine maintenance of the vehicle.

We also highly recommend on any modified car an increased oil service interval. Be sure to use oil that is VW 502 00 specification approved, and change the oil on a regular basis, preferably every three to five thousand (3000-5000) miles.

If you have any questions or concerns about the installation of your APR FSI Fuel pump, please contact APR Technical support at (800)680-7921 or (334)502-5181. An electronic copy of this document is available on the Customer Support section of APR's website, [www.goapr.com](http://www.goapr.com).



# Technical Service Bulletin

MIL on (DTC P2293 in ECM)

15 07 02 June 18, 2007 2013147/4. Supersedes Technical Service Bulletin Group 21 number 06-04 dated Dec. 11, 2006 due to addition of description of one of the main conditions that can result in the storage of P2293.

Model(s)	Year	VIN Range	Vehicle-Specific Equipment
A3	2006 – 2007	All	2.0TFSI Engine
A4	2005 – 2007	All	
A4 Cabriolet	2007	All	

## Condition

MIL on. The following DTC is stored in the ECM data memory:

- P2293 (Fuel pressure regulator 2 performance)

at times in combination with:

- P0087 (Rail fuel pressure too low)
- P1093 (Fuel trim 2, bank 1 malfunction)



## Technical Background

Excessive wear of the cam lobe (in the intake camshaft) that drives the high pressure fuel pump. This limits the maximum pump piston lift, causing fuel rail pressure fluctuations. The wear on the cam lobe also leads to wear in the base of the high pressure fuel pump cam follower.

## Production Solution

Increased surface hardening of the camshaft lobe for the high pressure fuel pump.

Improved intake camshafts have part number 06F 109 101 B.

## Service

# Technical Service Bulletin

1. Remove the high pressure fuel pump and visually inspect:
  - The base surface of the cam follower (Figure 1, Point 6) in contact with the camshaft lobe.
  - The tip of the high pressure fuel pump plunger.
  - The high pressure fuel pump camshaft lobe.

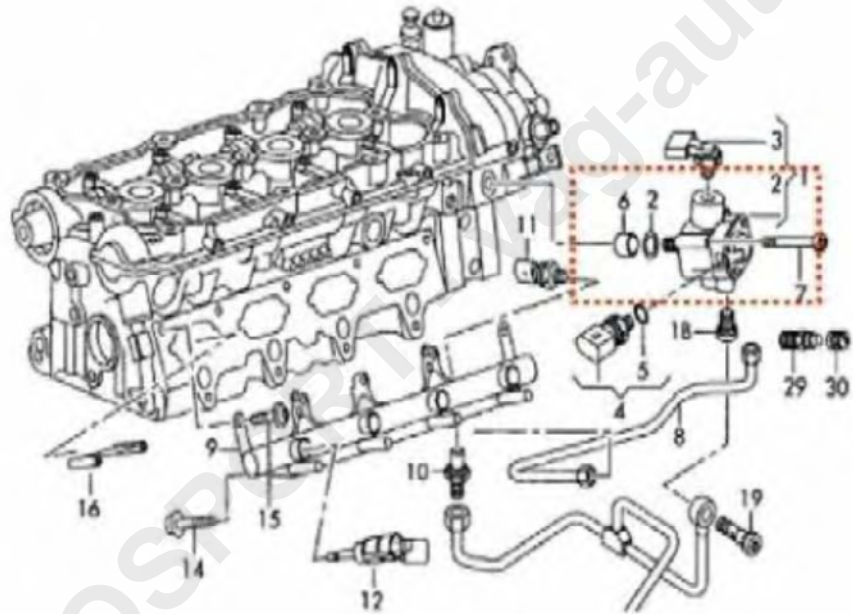

Figure 1. The high pressure fuel pump.

2. If the base of the cam follower looks like Figure 2, C or Figure 2, D, no excessive wear is present. The cam follower and camshaft should not be replaced.



Figure 2. Cam followers in various stages of wear: holed base (A), excessive wear (B), normal wear (C), and new part (D).

3. If the cam follower base surface is excessively worn so that its surface is concave (Figure 2, B) or altogether missing (Figure 2, A), or if the high pressure fuel pump camshaft lobe shows excessive wear (Figure 3), replace the intake camshaft and the cam follower.



Figure 3. Excessive wear on the lobe for high pressure fuel pump in the intake camshaft.

# Technical Service Bulletin

4. The high pressure fuel pump must be replaced only if the tip of the plunger shows excessive wear (Figure 4). This condition is only possible if the cam follower base is holed and the plunger tip has come in direct contact with the camshaft lobe.
5. If no excessive wear can be found in the high pressure fuel pump cam follower or intake camshaft lobe, or if the damage is found in camshafts with part number 06F 109 101 B, please create a Technical Assistance Contact Ticket under the Concern Type Engine and Engine Electronics in ElsaWeb. Attach the complete diagnostic log to the contact, and call the Audi Technical Assistance Center (Audi Helpline) for further assistance.



Figure 4. Excessive wear marks on the tip of the high pressure fuel pump plunger.



## Warranty

When procedure applies to vehicles within the New Vehicle Limited Warranty, use the following:	
Claim Type:	W2
Part Identifier:	1505
Damage Code:	1505 18 002 2
Labor Operations:	See ElsaWeb for appropriate labor operation
Diagnostic Time:	Diagnostic time reimbursement follows guidelines printed in Section 2.2 of the <i>Audi Warranty Policies and Procedures Manual</i>
Claim Comment:	As per TSB #2013147/4
All warranty claims submitted for payment must be in accordance with the <i>Audi Warranty Policies and Procedures Manual</i> . Claims are subject to review or audit by Audi Warranty.	

## Required Parts and Tools



# Technical Service Bulletin

---

Part Number	Part Description	Quantity
06F 109 101 B	Intake Camshaft	1
06D 109 309 C	Cam Follower	1

All parts and service references provided in this TSB are subject to change and/or removal. Always check with your Parts Department and service manuals for the latest information.

