



Responsibly enhancing
the driving experience.

APR BBK Installation Instructions

TL100172

Before starting:

Ensure your wheels will clear the calipers in your big brake kit. If you are not sure, please contact support at 800-680-7921 to request a copy of the “wheel fitment template” for your vehicle.

Your kit should include the following:

2x S6L 6-piston calipers pre-fitted with high-performance pads

2x aircraft grade aluminum mounting brackets

2x 2-piece floating rotor assemblies, marked ‘LEFT’ and ‘RIGHT’

2x stainless braided hoses including:

- 2x M10 banjo bolts

- 4x copper washers

4x high tensile radial mounting bolts & washers

2x rubber end caps



Removal of standard front brake components

- After securing the vehicle carefully on jack stands – remove the front wheels.
- Leave the cap tightly on the master cylinder reservoir. Loosening the cap will cause more brake fluid to drip/leak when removing the standard brake components.
- Place a drip tray directly below the area where the original rubber brake hose and steel ‘hard’ brake line from the chassis meet.

WARNING:

Brake fluid will damage any painted surface. We recommend keeping some warm, soapy water on hand during the entire installation process. Use this water to immediately clean spilled brake fluid from any painted surface.

- You will find two additional rubber caps supplied in your Big Brake Kit. These are to be placed over the end of the steel ‘hard’ brake lines, once the rubber brake hoses have been removed, to stop the brake fluid from dripping/running out during the installation process.
- While swapping the brakes, do not allow the master cylinder reservoir to run dry and draw air into the system, even if you plan on changing the brake fluid. Letting the brake fluid get too low can require the car to be connected to a dealership scan tool to fully bleed the brake system.

APR, LLC
4800 US Hwy 280 W
Opelika, Alabama
36801

800 680 7921 phone
334 502 5181 local
334 502 5180 fax
GOAPR.COM web



- Loosen the hard brake line tube-nut that connects the hard brake line to the rubber brake hose on the inboard side closest to the chassis.
- Place one of the rubber caps over the end of the steel 'hard' brake line immediately to limit brake fluid loss.
- Remove the stock caliper mounting bolts that fasten the caliper to the knuckle.
- Keep the stock caliper mounting bolts, which will be re-used to attach the APR caliper mounting bracket to the knuckle.
- Remove the stock caliper with the rubber brake hose still attached. Be aware that some fluid may leak from the open end of the rubber brake hose.
- Remove any retaining screws or bolts holding the stock brake rotor to the hub.
- Remove the stock brake rotor from the hub.

Fitting APR Big Brake Kit components

APR big brake kit components are labeled "LEFT" and "RIGHT". In all instances, it refers to the left or right of the vehicle when seated in the vehicle.

Fitting the mounting brackets

- The OEM dust/splash plate will need to be removed or trimmed per the rotor fitting instructions below. This may need to be done before the brackets are mounted.
- Clean the caliper mounting lugs on the knuckle using brake cleaner or solvent.
- Ensure that the stock caliper mounting bolts are clean and in good condition. Use brake cleaner or a solvent to clean the bolts if necessary. Apply a small amount of thread-locker to the threads of the stock caliper mounting bolts. **Weekend Track Day Customers:** We recommend that you torque check your axial mount bolts after every event. In this instance, do not use any thread locker on mounting bolts.
- Use the stock caliper mounting bolts to attach the APR caliper mounting bracket to the knuckle. (See vehicle Assembly Diagram for mounting bracket orientation).
- Torque the caliper bracket mounting bolts to 120Nm (89ft-lb).

APR, LLC
4800 US Hwy 280 W
Opelika, Alabama
36801

800 680 7921 phone
334 502 5181 local
334 502 5180 fax
GOAPR.COM web

Fitting the rotors

IMPORTANT:

There may be considerable rust/corrosion buildup that has formed on the mounting surface of the hub. It is essential that you thoroughly clean the mounting surface of the hub with a wire brush, Scotch-Brite™ or emery paper followed by a brake cleaner or solvent. The mounting surface of the hub must be perfectly clean. Failure to do this can lead to excessive run-out on your new brake rotors and result in the onset of brake judder.

Do not ignore this important step!

- Once clean – check the hub surface for any burrs or imperfections. Minor burrs may be removed using a fine-tooth file. Work carefully.
- Measure the runout of the newly cleaned hubs using a dial gauge. The runout on each hub should be in the 0.01mm – 0.02mm (0.0004 – 0.0008in) range. Do not fit your rotors to a hub with excessive runout, as this will result in brake vibration and damage to the new rotors.
- Wheel bearings must be in good condition and correctly torqued.
- The OEM dust/splash shield will need to be removed or modified to fit the new APR brake rotor. Test fit the new rotor by hand to ensure that the rotor sits flat against the hub face with a minimum of 3mm (0.1in) clearance between the rotor and dust/splash shield. If necessary, the shield must be removed or carefully bent away from the rotor to achieve the 3mm (0.1in) clearance. For track day use, APR recommends modifying the shield, rather than removing, to ensure the brake line and electrical connectors and wires are more protected from heat.

IMPORTANT:

Your new APR 2-piece rotors each have 72 directional cooling vanes. Be sure to fit the correct rotor to each side of the car. Reversing the rotor direction will substantially reduce the cooling efficiency of the rotors. The packet in which each rotor is sealed is clearly marked “Left” or “Right” side. The internal cooling vanes should “lean” to the rear of the car on the top side of the rotor (see below).

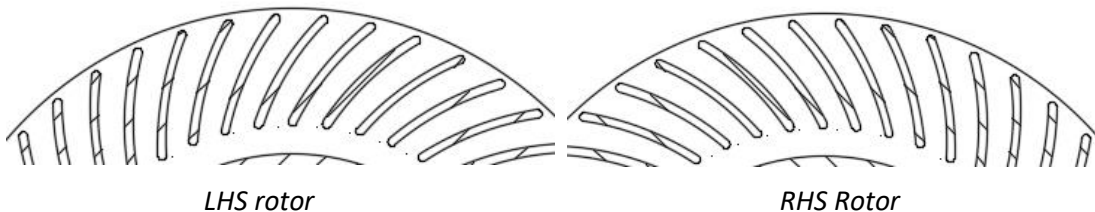



- Fit the rotor to the hub and use the wheel nuts (and spacers/washers if necessary) to hold it in place without the wheel. Tighten using moderate torque. Now measure the runout on the rotor friction surface, approximately 2.5cm (1in) from the edge of the rotor, using a dial gauge. The runout should be in the 0.05mm – 0.07mm (0.002 – 0.0027in) range and must not exceed 0.08mm (0.003in).
- If runout exceeds 0.07mm (0.0027in), remove the rotor and rotate it by one bolt hole and re-check. This can be repeated until the optimum (lowest) runout is achieved. The rotor and hub can then be marked for future indexing.

Fitting the calipers and brake lines

- APR uses a proprietary self-locking thread for the radial mountings in the caliper brackets. Do not use any thread locker / Loctite on caliper radial mounting bolts. Use a small amount of thread lubricant (such as *ARP Fastener Assembly Lubricant*) on the bolt threads. **Weekend Track Day Customers:** We recommend that you torque check your radial mount bolts after every event.
- Fit the new APR caliper to the bracket installed earlier, using the M12 mounting bolts and washers supplied. The washers must be fitted underneath the bolt heads, not underneath the caliper. **Torque the radial mounting bolts to 105Nm (77ft-lb).**



NOTE:

Your APR calipers are shipped from the factory with the brake pads already installed to make kit fitment as simple as possible. Simply spread the pads to either side and then slide the caliper over the rotor. For fitment of new pads, refer to Appendix 2.

APR, LLC
4800 US Hwy 280 W
Opelika, Alabama
36801

800 680 7921 phone
334 502 5181 local
334 502 5180 fax
GOAPR.COM web

IMPORTANT:

Ensure that the caliper is perfectly centered over the rotor and that no part of the caliper is fouling the rotor at all.

With the caliper mounted to the bracket, measure rotor to caliper clearance on either side (A and B below). The difference between the two dimensions must not exceed 1.0mm (0.04in) either at the top or bottom of the caliper.

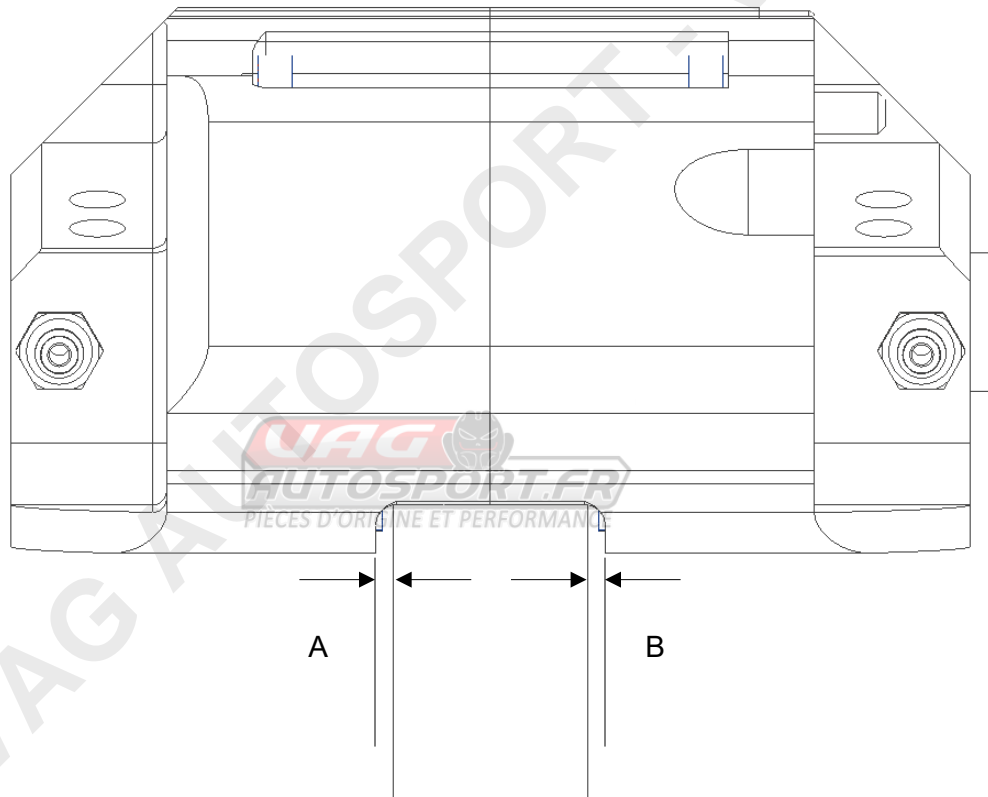
**NOTE:**

For vehicles with splash plates mounted behind the hub: If you have completely removed your vehicle's splash plates, it will affect the caliper centering since the hub has now moved more inboard. You may have to cut the center of the splash plate out and reinsert it behind the hub to get the centering correct.

Install the APR stainless steel braided brake hose with the banjo fitting at the caliper end and the female fitting at the steel hard-line. After removing the red plastic tab from the caliper fluid inlet, install the banjo bolt into the caliper with a copper washer on each side of the banjo fitting as per the image below:

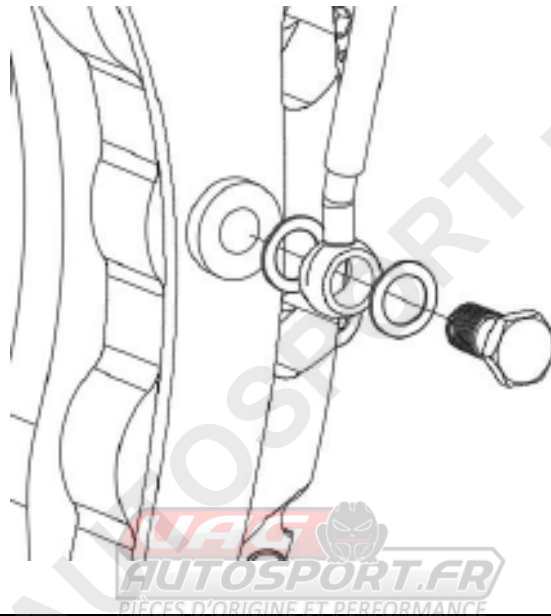
**WARNING:**

Failure to use a copper washer on either side of the banjo fitting can result in a leak and loss of brake system pressure under braking.

- Align the neck of the banjo fitting in the direction of the brake hose locating bracket on the shock strut.
- Torque the banjo bolt to 20Nm (15 ft-lb).
- If applicable, slide the rubber grommet on the brake hose into the locating bracket on the strut. The hose should be free to move within the grommet.
- If applicable, secure the female fitting of the new hose to the locating bracket on the chassis using the stock spring or clip. If this is not possible then use a cable tie to secure the female fitting to the locating bracket.
- Remove the rubber cap from the end of the hard brake line and immediately screw the tube nut on the hard line into the female fitting on the flexible brake hose. Ensure that the fittings are tight but do not over-tighten them.

IMPORTANT:

Turn the wheels full-lock to full-lock, while carefully checking that neither the caliper mounting bracket or the brake hose are binding or fouling in any way. If necessary, adjust by re-clocking the banjo fitting in order to re-direct the brake hose. Re-tighten the banjo bolt to 20Nm (15 ft-lb) once done.

The process described above is the same for both sides of the car. Complete the installation of the APR components on both sides of the car before bleeding the brakes.

Bleeding the brakes

- The S6L caliper features two bleed nipples both mounted to the inboard side of the caliper. The internal fluid channels in the S6L caliper are angled to ensure all air can be expelled during the bleeding process. It is recommended to use the top bleed nipple during initial bleeding of the caliper. The bottom bleed nipple can be cracked open slightly before final bleeding to ensure any air trapped is expelled. Final bleeding should only be done through the top bleed nipple.
- The new brake hoses and calipers will have to fill with fluid during the bleeding process. This will quickly drain the master cylinder reservoir. Do not allow the master cylinder reservoir to run dry and draw air into the system. Doing so may require the brake system to be serviced by a dealership. You will need to top up the master cylinder reservoir regularly with new brake fluid while bleeding.
- Use a clear bleed tube and **bleed bottle** when bleeding. The clear tube should fit tightly onto the heads of the bleed screws to avoid brake fluid spilling onto the calipers and brake pads. It is very important to avoid contaminating the brake pads with brake fluid as this will reduce brake efficiency. The APR logo on the caliper is laser etched into the anodizing, so it will not be affected by brake fluid. An 11mm bleed nipple wrench has been supplied with the kit to aid with bleeding (see below). Keep the wrench with your big brake kit for future service bleeds. Should it be lost, a new wrench can be ordered from FACOM (part # 76.11)

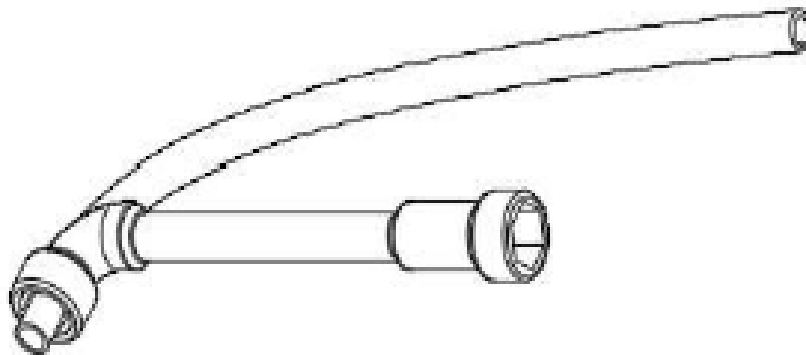

Pass the bleeder pipe through the back of the tool and onto the bleed nipple

- Use a brake fluid that is compatible with the seals in your brake system. APR recommends Glycol based brake fluids that meet DOT 4 specifications or higher. Do not use Silicone based brake fluids with APR calipers. For recommendations on specialized high-temperature or competition brake fluids, please contact APR support at 800-680-7921.
- The sequence for bleeding the brakes should be:
 1. Passenger outboard bleed screw.
 2. Passenger inboard bleed screw.
 3. Driver outboard bleed screw.
 4. Driver inboard bleed screw.
- After initially bleeding the system, gently tap each caliper body on the inboard side with a non-marring mallet to dislodge any small air bubbles that may be trapped.
- Re-bleed the system a final time using the sequence above.
- Tighten all bleed screws to a torque of 17Nm (12.5 ft-lb).
- Once the bleeding is complete we recommend you soak up excess brake fluid remaining in the bleed screw. Roll a piece of tissue paper into a thin strip and insert into the bleed screw to soak up the fluid. Repeat this procedure for each of the four bleed screws until the tissue remains dry and is soaking up no more brake fluid:



- Place the rubber bleed screw caps provided onto each bleed screw.
- Get a helper to apply a constant pressure to the brake pedal while you check all connections, including bleed screws and both end of each brake hose for leaks.
- MAINTENANCE: APR recommends flushing the brake system with new brake fluid every 24 months.

NOTE:

On a dry bleed (first time bleed on a new caliper) some air may be trapped in the very tight tolerances between the caliper pistons and bores, resulting in a slightly spongy brake pedal. The vibration and suspension movement experienced under normal driving conditions will cause these small air pockets to rise to the top of the calipers, near the bleed screws for easy bleeding. If you do not achieve a perfectly firm pedal after normal bleeding (as described above), we suggest driving the car for ± 30 miles (50km) before doing a final bleed. This will result in the best possible pedal feel. If you are a workshop, we suggest driving the car for a few miles and then re-bleeding or asking the customer to drive for a few days before returning for a final bleed. (This does not apply in cases where there is excessive pedal travel after initial bleeding, in which case the system should be checked for leaks, but only in cases where the driver feels that the pedal is not quite optimal).

Re-installing the wheels

It is essential to carefully check wheel / caliper clearance before re-installing the wheels. Many people are under the mistaken impression that wheel diameter is the most crucial clearance to check for. This is incorrect. Wheel spoke clearance with the outboard caliper face is more often problematic! APR cannot possibly check all wheels for any specific vehicle. Wheel clearance is the vehicle owner's responsibility. Some wheels may require spacers to clear the calipers. If this is the case, please contact APR support at 800-680-7921 for recommendations.

Some wheels are balanced using adhesive backed lead on the inboard side of the wheel. If the weights have been placed on the outboard edge (closest to the wheel spokes) they may interfere with the caliper as the wheel rotates. If this is the case, note the position and weight and place a new weight slightly further inboard on the wheel in order to clear the caliper. Alternatively, have your wheels re-balanced by a certified technician, once you have explained the situation to him clearly.

- Re-install the wheels and torque the wheel nuts to the manufacturers recommended specifications.
- Rotate the wheels while the car is still on the jack stands and check one last time to ensure that the wheels and wheel spokes clear the calipers by at least 2mm (0.08in).
- Lower the vehicle back onto the ground safely.
- Before test driving the vehicle. Pump the brake pedal numerous times to 'snug' the pads up to the rotors. Ensure that you have a firm brake pedal.
- Carefully test drive the vehicle at low speed in a safe area to ensure that all brake components are working correctly before continuing to the bed-in procedures described next.



Bedding-in your new APR rotors/pads

- Drive slowly for 1 week (minimum 180 miles / 300km) to establish a proper wear pattern and maximum contact area between pads and rotors. Use medium brake pedal pressures and do not test the performance of your new brake setup during this time. Hard braking at this stage will ruin your new rotors and pads. Long open-road trips do not count as you are not using your brakes regularly enough. Only use brakes hard in an emergency. Never left foot brake or drag the brakes!
- At any point after completing your 180 miles, perform 6 consecutive brake applications from 65mph (100 km/h) to 20mph (30km/h), starting with an easy pedal pressure for the first application and building to about 70% of max pressure for the last two applications. Do not actually stop the car at any stage during this procedure. Brake only to 20mph (30km/h). You may experience some brake fade and smell the pads from the 5th application onwards. This is not a problem.
- Drive home using the brakes as moderately as possible, allowing the airflow through the rotors to cool them. Park the car and let your brakes cool down completely. This last step (the cooling cycle) is important.

How to get the maximum wear life from your rotors and pads:

- Be sure that you have followed the fitment and bed-in instructions on the flip side of this page.
- Do not run your rotors at temperatures over 630° C (1166° F). Doing so will substantially reduce product life. All APR rotors feature a MTR (Maximum Temperature Recording) system. This consists of different levels of thermally sensitive paint that is applied to the outside diameter of the rotor. Each of the paints will change color at a specific temperature, hereby providing a permanent record of the maximum temperature reached by the rotor. The paints will change only once, so it is recommended that you gradually build up your driving style after bedding in the rotors and monitor the MTR paints after each driving session. This will start to give you a basic idea of what rotor temperatures your driving style is producing. For maximum rotor life, temperatures should be kept under 630° C (1166° F).

Blue paint - turns Light Brown at 275° C (527° F).

Green paint - turns White at 460° C (860° F).

Orange Paint - turns Yellow at 550° C (1022° F).

Red / Pink paint - turns White at 630° C (1166° F).

Wide Red paint strip – various shades from 104 – 1270° C (219 – 2318° F). *

*** Contact APR support at 800-680-7921 for more info**

APR, LLC
4800 US Hwy 280 W
Opelika, Alabama
36801

800 680 7921 phone
334 502 5181 local
334 502 5180 fax
GOAPR.COM web



- Though many other pad types will fit these calipers, APR exclusively recommends the pads that come with the kit. These pads have proven suitable for daily use and track use up to the temperature limit of the rotors and calipers. If you do want to try different brake pads in your APR brake setup (at the risk of voiding your warranty on the APR brakes), contact us for more pad options and pad part numbers.
- Warm up your rotors prior to hard driving. It is best to get some heat into your rotors by driving moderately prior to spirited driving sessions - involving heavy, consecutive braking.
- Slow down about 3-4 miles before you park the car. It is important that you do not park your car with extremely hot rotors. After a spirited driving session, you should slow down and use the brake as moderately as possible for about 3-4 miles prior to reaching your destination. This allows rotor temperatures to come down to an acceptable level prior to parking the car.
- Nothing stresses brake rotors and pads like heavy, consecutive braking between traffic lights. If you are prone to do this, it is recommended that you limit heavy braking to 3-4 consecutive intersections before driving on and allowing airflow to cool the rotors for a few minutes. Use the brakes only mildly during this cooling period and, if possible, do not bring the vehicle to a complete stop. It is important that you continue moving to allow airflow to cool the rotors.
- Never intentionally wet your rotors when they are hot. Be careful of using drive-through car washes when rotors are hot.
- All APR calipers feature temperature recording strips applied to the inboard surface of the calipers. The white 'line' in the centre of the strip will turn dark in dictating the maximum temperature reached by the caliper. For maximum seal life, temperatures should be kept below 200° C (392° F). Caliper temperatures of around 200° C (392° F) will lead to reduced seal life. If a brake caliper reaches 250° C (492° F) the seals should be replaced immediately. New seal kits can be ordered directly from APR.
- As the APR kit is a performance product, and due to the properties of materials used during construction, braking may be associated with elevated levels of noise, vibration and harshness. This is normal and will not impede brake performance or safety.
- **DO NOT use aggressive wheel cleaners that contain strong acids. They will discolor the caliper and rotor hat finishes.**

Appendix 1 (Torque settings)

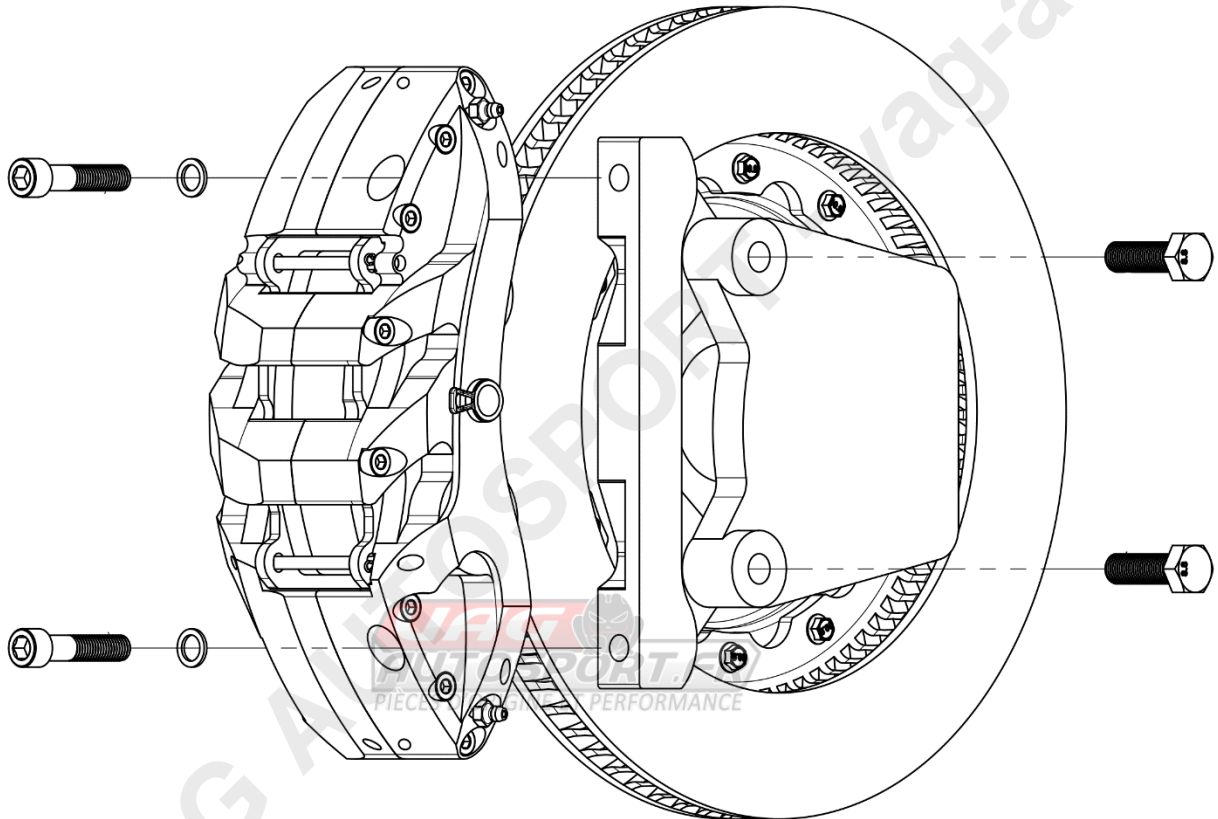

Mounting bracket to upright (OE bolts)	125Nm (92 ft-lb)
Caliper to mounting bracket (M12 bolts supplied)	105Nm (77 ft-lb)
Banjo bolt for caliper fluid inlet (M10 x 1.0mm)	20Nm (15 ft-lb)
Caliper bleed nipples (M10x1.0mm)	14-17Nm (10-12.5 ft-lb)

Appendix 2 (Changing pads – S6L Caliper)

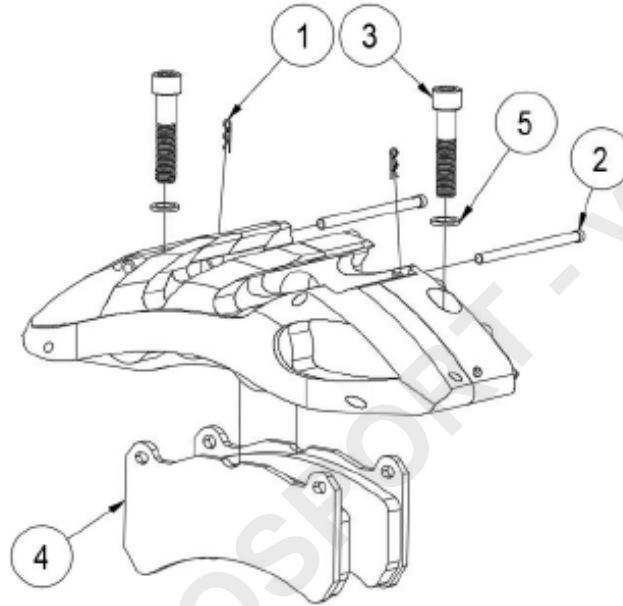

The international standard width for the pads used in the S6L caliper is 164.50mm. If the replacement pads you are fitting is wider than 164.50mm the edges need to be filed to fit.

PIÈCES D'ORIGINE ET PERFORMANCE

To remove and replace pads on the S6L caliper, follow the steps below:

- 1) Remove the two R-clips (#1) from the pad retaining pins. Use a thin screw driver or hook/pick set to lever the R-clips upwards. Be careful not to lose them.
- 2) Push the pad retaining pins (#2) out from the front of the caliper. They can be knocked out using a 5mm punch and a light hammer.
- 3) Remove the caliper by undoing the two radial mounting bolts (#3) using a 10mm hex driver (Allen key) and hang the caliper onto the strut with a zip-tie. Do not disconnect the brake hose and do not let the caliper hang on the brake hose as it may cause damage to the hose.
- 4) Slide the pads out at the bottom of the caliper (#4).
- 5) Clean around piston walls with brake cleaner before pushing them back into the caliper body.
- 6) Refit your new pads by sliding them up into the caliper. There is some resistance to the pad sliding in, this is the tensioning plate in the caliper and is normal.
- 7) Re-fit the pad retaining pins (#2).
- 8) Fit the caliper back onto the bracket and torque radial mount bolts (#3) to 105Nm (77 ft-lb).
- 9) Refit R-clips (#1). IMPORTANT – do not drive without R-clips fitted.



Appendix 3 (Changing rotors)

- 1) Remove the caliper by undoing the two radial mounting bolts using a 10mm hex driver (Allen key) and slide the caliper away from the rotor. Do not disconnect the brake hose nor let the caliper hang by the brake hose.
- 2) Remove the rotor/hat assembly.
- 3) Using a 10mm socket, remove the old mounting hardware and separate the rotor from the hat. Know that these bolts have thread sealant and are hard to break loose.
- 4) Ensure the hat is clean and free of any debris. Then, attach the new rotor to the hat and use the new hardware to secure. It is imperative that you apply Loctite 272 to the threads of each bolt and torque each bolt to 11.5Nm (8.5 ft-lb).
- 5) Fit the caliper back onto the bracket and torque radial mount bolts to 100Nm (74 ft-lb).

WARRANTY:

The Manufacturer will guarantee any product manufactured by the company that is found to be faulty in workmanship or materials within 12 months or 12,500 miles of use (whichever occurs first).

The warranty does not extend to faults or failure caused by ordinary wear and tear, misuse/abuse, use of the product for any form of motor sport or track-day use, incorrect fitting, use of incorrect or defective associated component parts (e.g. pads), or any cause not relating to a defect in design or manufacturing.

IMPORTANT: All APR rotors and calipers feature MTR (Maximum Temperature Recording) tabs that are applied to the outside diameter of each rotor and the inboard side of each caliper. The above warranty is **VOID** if any APR rotor is run to maximum temperatures in excess of 630° C (1166° F) or any APR caliper is run to maximum temperatures in excess of 200° C (392° F).

APR, LLC
4800 US Hwy 280 W
Opelika, Alabama
36801

800 680 7921 phone
334 502 5181 local
334 502 5180 fax
GOAPR.COM web