

Super Duper Charger System



034 MOTORSPORT

Süpercharge the performance of your B8/8.5 Audi S4/S5 with the 034Motorsport SüperDüper Charger 84mm Throttle Body System. The purpose of this kit is to improve power beyond the factory throttle body found on the supercharged 3.0 TFSI engine in the B8/8.5 S4/S5s, in a clean and cost-effective package.

***Be sure to clean out any intake related components to remove any possible contaminants.**

Installation Spiciness Rating: MILD



Installation of your new 034Motorsport SüperDüper Charger 84mm Throttle Body System is a straight forward process that will take approximately 1 hour.

Supplied Parts:

- 84mm Throttle body
- SD Throttle body adapter
- Throttle body harness
- Throttle body gasket (Gasket material may vary)
- Silicone intake hose with barbed nylon fitting
- #56 Hose clamp
- #64 Hose clamp
- (4x) M6x50 socket head bolts
- (4x) M6x20 socket head bolts
- (8x) M6 lock washers

Tools Needed:

- T30 Torx bit
- T25 Torx bit
- 5mm ball-end Allen key
- Flathead screwdriver
- Swivel adapter

About This Guide

This Install Guide documents the installation process on a B8 Audi S4. There may be minor differences depending on specific vehicle, market, options, etc.

We also installed the 034Motorsport S34 Intake system, which we highly recommend for the ultimate fitment and finish!

Getting Started

Confirm you have received all the parts included with your purchase by reading the complete guide, if there are missing components, please contact:

customerservice@034motorsport.com

Install Steps

Step 1

Open your hood to access the intake system.



Step 2

Using a T30 Torx, remove the 6 fasteners holding the radiator cover. Gently pull the cover upward.



Step 3

Remove the two T25 screws from the stock inlet scoop and remove the scoop from the OE air box.



Step 4

Separate the two duct pieces. We will reinstall the part with the mounting tabs later.



Step 5

Remove the engine cover and set it aside.



Step 6

Unclip the two rubber lines from the OE intake tube and then loosen the inlet tube clamp. (Ours is a 6mm)



Step 7

Remove the vacuum line from the intake.



Step 8

Unhook the secondary air injection hose by squeezing the tabs and pulling downwards.

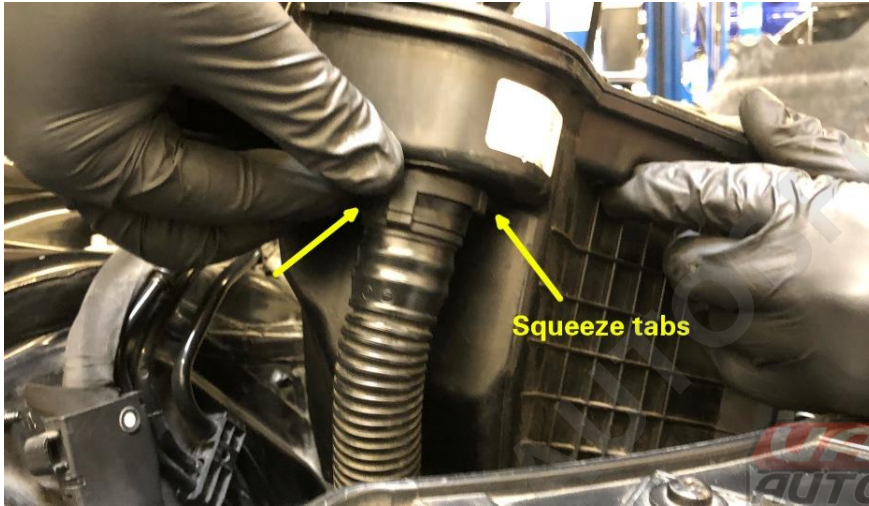

Step 9

Remove the OE intake system by rotating and pulling out the side of the vehicle as shown. (CAUTION: Avoid stressing the fuel lines unless you really like fire)



Step 10 (optional parts shown)

Assemble/Install the S34 intake system, instructions found here: [S34 Intake Assemble/Install](#)



Step 11

Using a T30 Torx, remove the hardware connecting the throttle body to the supercharger inlet.



Step 12

Disconnect the harness from the throttle body and set the throttle body, spacers, and o-rings to the side.

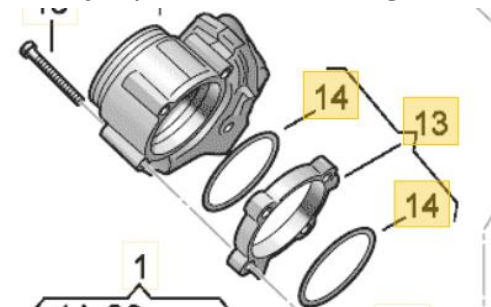

Step 13

The black bracket will need to be bent upwards for the adapter to fit. Make the bend after the engine cover mount.

**Step 14**

Sandwich the provided throttle body gasket between the adapter and the supercharger inlet.

**Step 15**

Using a 5mm Allen bit, attach the adapter to the inlet with the provided M6x20 bolts. Torque to **11Nm**.

**Step 16**

Now attach the new throttle body to the adapter with the provided M6x50 bolts. Torque to **11Nm**.

**Step 17**

Attach the harness to the new throttle body.

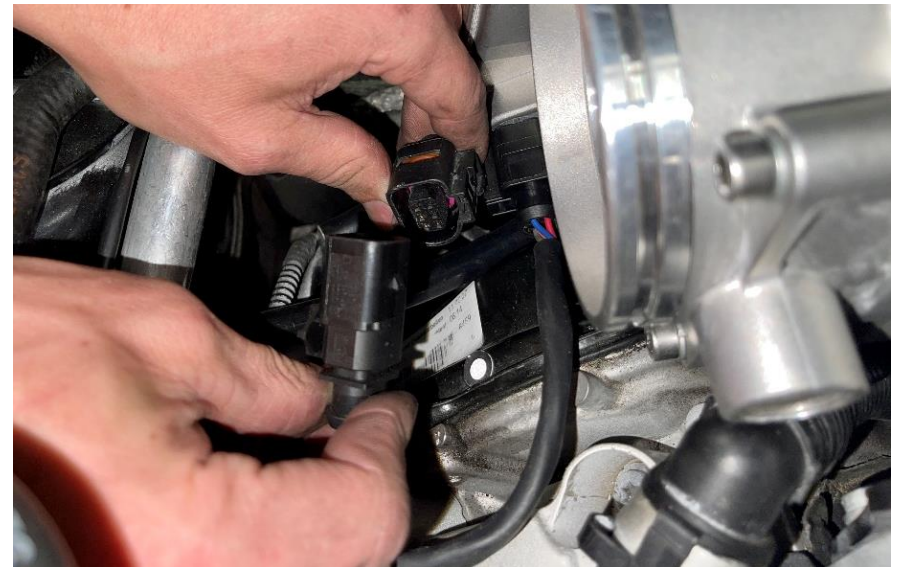

Step 18 (optional parts shown)

Slide the silicone hose into the carbon heat shield and complete the rest of the S34 installation.



***If you are not using the S34, you will need to attach an air filter of your choice to the silicone hose.**

Step 19

Slide the silicone hose onto the new throttle body and tighten the hose clamp.

Step 20

Reinstall the air duct onto the radiator support.



Step 21

Reinstall the radiator cover.



Step 22

You are finished with the installation. Enjoy!



If you are planning to use the factory engine cover, the rear piece will need to be notched to fit around the SüperDüper throttle body adapter.

NOTE: A successful throttle body adaptation (and accompanying upgraded TB software) is required for successful operation of this product on the vehicle.