

CATCH CAN KIT, 8J/8P AUDI TT/A3 & MKV/MKVI
VOLKSWAGEN GTI/GLI 2.0 TSI**034 MOTOR SPORT**

This kit is designed to prevent oil from depositing in the intake manifold and intake valves, resulting in drastically reduced carbon buildup and extended life of the intake manifold flapper assembly.

Installation Spiciness Rating: MILD

Installation of your 034Motorsport TSI Catch Can Kit is a straightforward process that will take approximately one hour to complete.

Supplied Parts:

- Mk5/Mk6 TSI Catch Can with Mounting Bracket
- Mk5/Mk6 TSI -10 AN Breather Hoses (2x)
- Mk5/Mk6 TSI Valve Cover Breather Adapter
- TSI Intake Manifold Plug with Boost Tap
- -10 AN Hose Separator
- M6x25mm Bolt (8)
- M6x20mm Bolt (1)
- Mk5/Mk6 TSI Catch Can Oil Drain Kit (Optional)

Tools Needed:

- T30 Torx Driver
- T27 Torx Driver
- T25 Torx Driver
- 16mm Socket
- 17mm Socket
- -10AN Wrench or 1" Hex Wrench

About This Guide

This Install Guide documents the installation process on an Mk5/Mk6 VW GTI and an 8J Audi A3. There may be minor differences depending on specific vehicle, market, options, etc.

Getting Started

Confirm you have received all the parts included with your purchase by reading the complete guide, if there are missing components, please contact:

customerservice@034motorsport.com



Installation Steps

Step 1

Remove your engine cover by using your hands and/or opposable thumbs to pull up on the plastic cover.

Step 2

Locate and remove the factory valve cover breather to intake manifold hose. Remove by pinching the plastic clips at the raised tabs at each end and sliding the hose firmly out. (shown in the red circles below)



Step 3

Install the 2.0 TSI Intake Manifold Plug to block off the port where the valve cover breather to intake manifold hose was. Rotate the locking tab down to secure the plug against the plastic rib on the intake manifold plenum. If you intend to use this as a boost tap, unscrew the 1/8" NPT Plug, and replace it with a 1/8" NPT to appropriate barbed brass fitting for use with your boost gauge's vacuum line.

**Step 4**

Unbolt the T30 Torx screw securing the coil harness loom and unplug the coil harness from all 4 coils. Remove the T25 Torx screw securing the PCV assembly to compressor inlet tube to the valve cover and pull to remove the tube from the PCV assembly.

Step 5

Remove the 9 T25 Torx screws securing the factory PCV assembly to the valve cover and remove the PCV assembly.

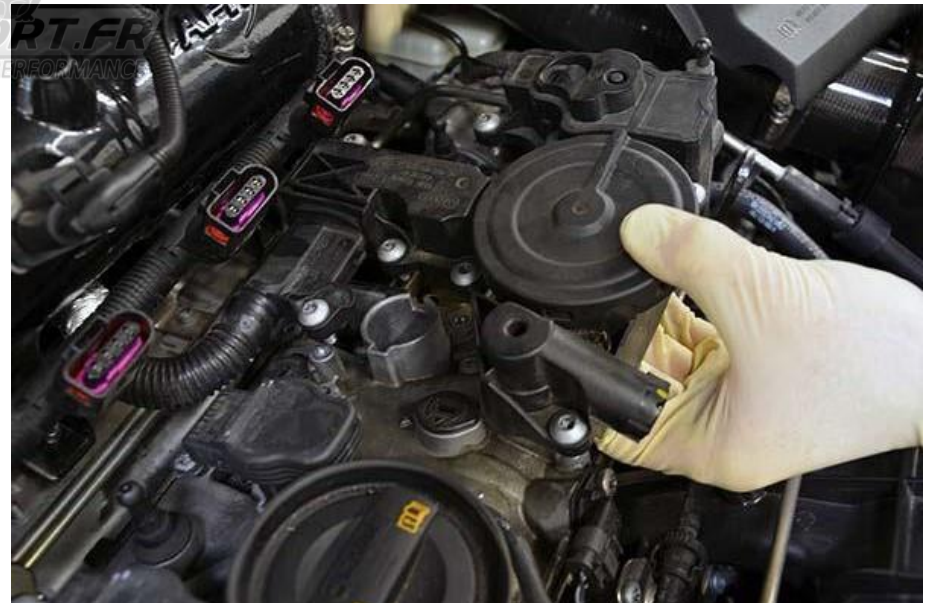

*Be careful to avoid dropping any screws into the holes in the valve cover.

Step 6

Remove the factory rubber seal (in green) from the PCV assembly and install it into the Valve Cover Breather Adapter.

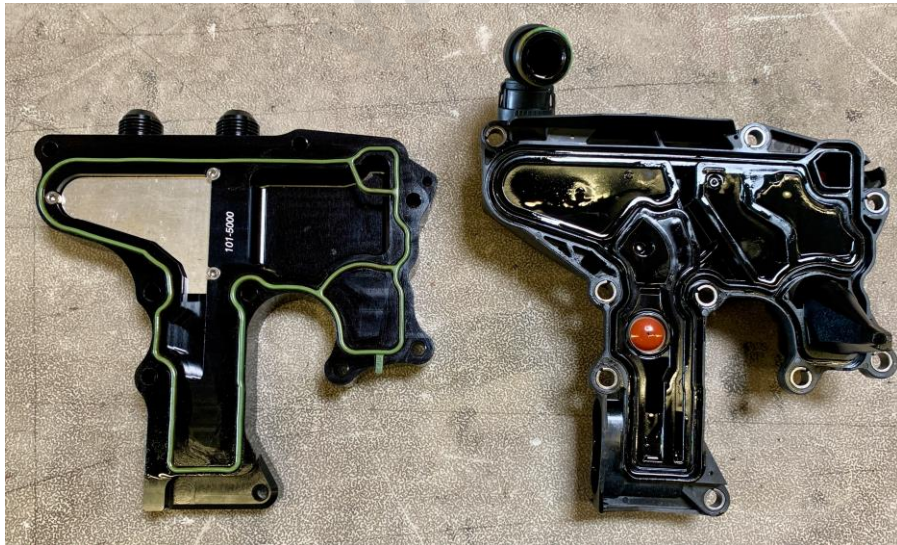
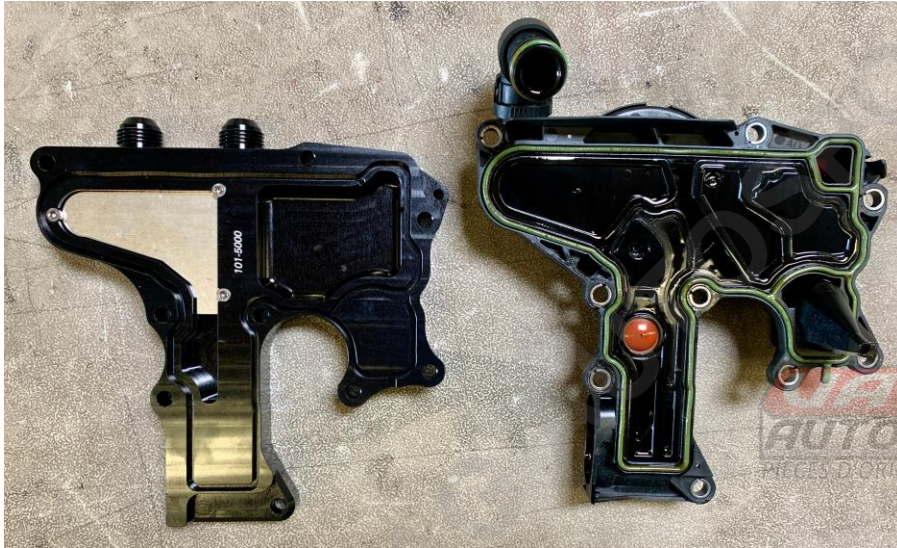
**Step 7**

Position the 034Motorsport Valve Cover Breather Adapter such that the holes align with the threaded holes in the valve cover and push the PCV assembly to compressor inlet tube into it until it seats.

Step 8

Secure the Valve Cover Breather Adapter to the valve cover using the supplied M6x25 bolts, and the M6x20 bolt (shown in the red circle below) Secure the PCV assembly to compressor inlet tube to the valve cover using the factory T27 Torx screw.



Step 8.5

Torque the bolts down to **11Nm** in this order.

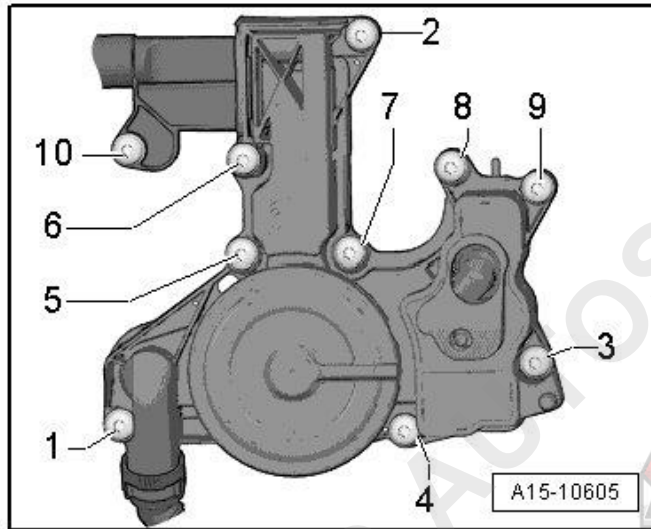
**Step 9**

Plug the coil harness back into all four coils, and secure the loom using the factory T30 Torx screw. Reinstall the coils.

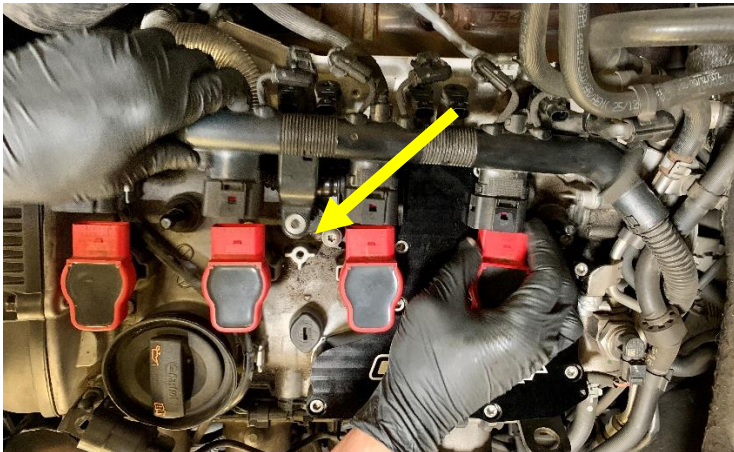

* If you are installing the optional oil drain kit, skip ahead to the instructions for installing the oil drain kit before mounting the catch can.

Step 10

Remove the front bolt from the passenger side engine mount. The catch can will mount to this location.

**Step 11**

Mount the catch can to the passenger side engine mount reusing the factory bolt.



Step 12

Route the -10 AN Breather Hoses as pictured below, and secure to the Valve Cover Breather Adapter and Catch Can. Install the hose separator over the hoses and secure using the Allen bolt as pictured.

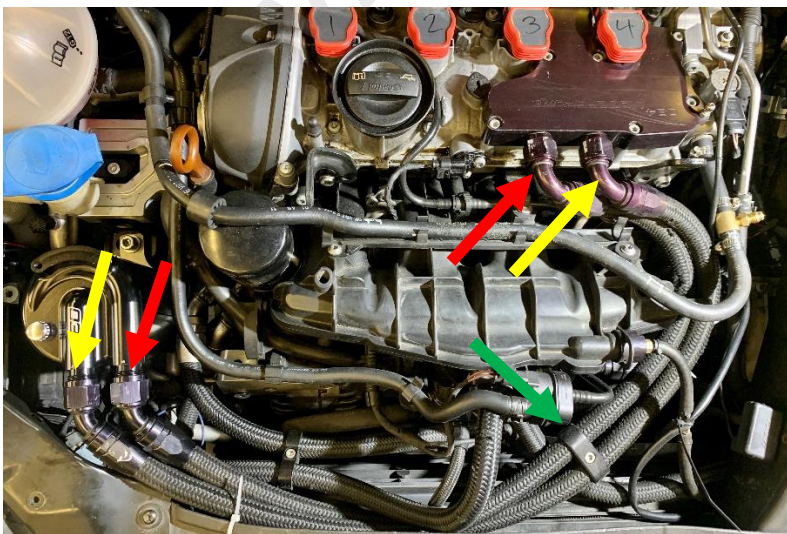

Step 13

Reinstall your engine cover by using your hands and/or opposable thumbs to push the plastic cover down onto the locating tabs. Enjoy!



*Draining the catch can - The Catch Can may be drained by unbolting the assembly from the engine mount and accessing the 1/8" NPT Plug at the bottom of the can. The assembly can also be completely disassembled by unscrewing the top and bottom plates from the body. Be careful of the o-ring seals when reassembling the catch can.

Installing the Optional Oil Drain Kit

Step A

Before mounting the catch can to the engine mount, remove the NPT plug from the bottom of the catch can, and replace it with the supplied NPT to push-lock Fitting as shown. Then, install the catch can as shown in Step 10.



Step B

Route the line for the oil drain away from any belts and pulleys, and secure it using the provided zip-ties. It needs to run from the catch can to the oil drain plug on your oil pan.

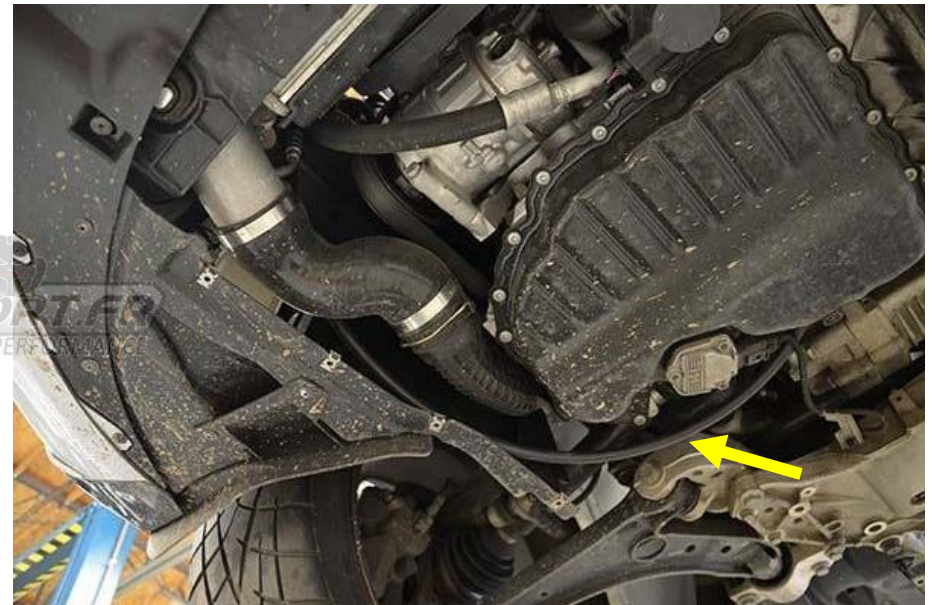

Step C

Drain your oil by removing the factory oil drain plug. If you drain it into a clean pan, it can be reused. If you do not wish to reuse it, you can perform an oil change at this time.

**Step D**

Push the oil drain line from the catch can onto the supplied push-lock banjo fitting. Install the banjo bolt through the fitting, and into the oil pan to replace the oil drain plug. The correct stacking order should be: Oil Pan > Washer > Banjo Fitting > Washer > Banjo Bolt.

**Step E**

Fill the vehicle with the appropriate amount of oil. Trim any zip-ties. Make sure than all lines are secured properly and routed correctly.